

Performance Pandemonium: Designing & Modifying the ETFE Skylight System for the Calgary Zoo's Panda Passage Exhibit

By Jelena Bojanic, B.Sc., EIT, Project Engineer, Read Jones Christoffersen Ltd.

The former Eurasian Gateway & Elephant Crossing at the Calgary Zoo has been re-used and re-adapted multiple times since 1963 to house animals, including elephants, giraffes, and the more recent rhinos and Komodo dragons. In 2015, the Calgary Zoo announced the Giant Pandas would be transferred from Toronto in 2018 and would be housed in the former Eurasian Gateway building at the Calgary Zoo.

The well-being of the pandas was predicated on creating a habitat in which the animals would thrive. The Calgary Zoo, along with the support of the project design team, decided to install two new ethylene tetrafluoroethylene (ETFE) skylights above the panda exhibit. ETFE is a highly transparent material over a wide spectrum of natural light, which would provide better conditions for the pandas.

Read Jones Christoffersen (RJC) provided technical support for design considerations, including snow and wind design loads, hail impact, temperature fluctuations, and recommendations to address inherent air barrier deficiencies and thermal bridging. Support was also provided during the installation to ensure the intended design parameters were achieved and that performance aligned with current industry standards.

The ETFE skylights were designed and manufactured in Germany and installed by a local contractor. These are some of the first ETFE installations in western Canada.

BACKGROUND

The ETFE skylights were proposed for this project because the material is one of the few tensile fabrics used for roofs that allow UV light to pass through and complies with the living building challenge “Red List” material restrictions. Other important considerations for choosing this product included cost, future recyclability, embodied energy, durability, chemical resistance, etc. RJC’s Calgary office, along with a few other offices (Edmonton, Toronto, and Vancouver) worked together to research a product that incorporated key design objectives and was within the client’s budget.

Originally invented for the aeronautics industry, ETFE was introduced to the construction industry in the 1980s and has since been used on projects around the world. It is a lightweight material, weighing approximately one per cent of the weight of glass, and allows up to 95 per cent of light transmission. The latter can be adjusted by varying the number of cushions and applying films. Thermal



Da Mao, an adult male giant panda, in Panda Passage. Photo credit: Calgary Zoo, www.calgaryzoo.com.

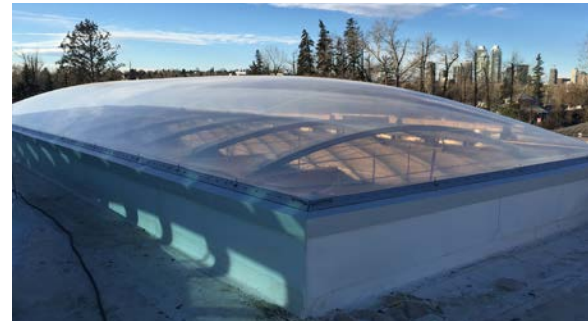

Two new ethylene tetrafluoroethylene (ETFE) skylights above the panda exhibit. ETFE is a highly transparent material over a wide spectrum of natural light, which provides better conditions for the pandas.

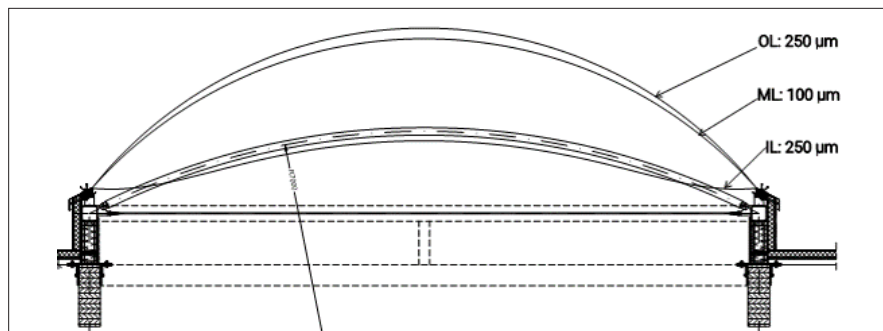

Figure 1. A manufacturer’s drawing showing the thickness of the layers in the ETFE skylight.¹

performance is higher in a three-layer ETFE system versus a single-layer system. To incorporate the new dome-shaped ETFE skylights above the panda exhibit, the existing glulam beam-supported metal roof deck underwent structural and building envelope modifications.

DESIGN CONSIDERATIONS

There were several design considerations the team had to take into account while working on this project, from cushion design and the supporting structure to the air barrier and drainage, and to thermal performance.



1 CUSHION DESIGN AND SUPPORTING STRUCTURE

For the ETFE skylight to resist specified snow and wind loads and hail impact, the design was focused on the individual foil thickness, number of layers, and internal cushion pressure. The cushions are inflated with a built-in blower/compressor that maintains air between the individual layers and pre-stresses each layer, resulting in a dome-shaped skylight that is stable against wind and snow loads.¹ The skylight manufacturer used RJC's recommendations for snow and

wind loads and Calgary's temperature fluctuations to ensure conformity with the local standards.

RJC posed the question regarding hail impact damage testing for the ETFE. The manufacturer provided a paper outlining test results from experiments conducted in Zurich and Switzerland. It also highlighted case studies with hail damage. The results showed that ETFE can, indeed, be damaged by hail, depending on the size of individual hail pieces and the temperature of the film itself.² The extent of damage varies from dimpling of the surface to full puncturing.²

Given that Calgary, Alberta experiences severe hailstorms during spring and summer months, with hail pieces ranging from 25 to 50 millimetres in size, this was an imperative design load to consider. The solution was incorporating a three-layer system with a slightly under-inflated outer cushion. The inner and outer layers (IL and OL) are each 250 micrometres thick, while the middle layer (ML) is 100 micrometres thick, as shown in Figure 1 (on page 15).

The two cushions are inflated to different internal pressures, with the inner cushion at 300Pa, and the outer at 250Pa.¹ The translucency of the ETFE foil was reduced slightly, with a three-layered system; however, the resultant light transmittance was approximately 76 per cent,³ which was within an acceptable range for the panda exhibit. The inner ETFE layer is supported by steel pipe arches fastened to steel perimeter beams made of square tube sections. The beams are further supported by steel columns, which are also made of square sections. Tension rods are incorporated throughout the frames to mitigate deflection of the structure.

2 AIR BARRIER AND DRAINAGE

The air barrier plane for the ETFE system relies on multiple components, including the ETFE foil, the ethylene propylene diene monomer (EPDM) edge gasket, the EPDM cover gasket, and the air barrier membrane tied from the aluminum profile to the existing roof deck. The manufacturer's shop drawings had inherent air barrier and drainage flaws. The design showed a condensation gutter that drained externally through the air barrier membrane (see Figure 2, part 23, on page 17) via four drainpipes, two on each of the east and west elevations and none on the south and north elevations. The drainpipes were positioned at quarter-points with a large spacing. A metal sheet section was shown to extend from the underside of

WHITE ROOF

HYDROTECH'S PROTECTED MEMBRANE ROOF
WHITE ROOF ASSEMBLY : IDEAL CHOICE FOR PROJECTS WITH HIGH REFLECTIVE OBJECTIVES

MONOLITHIC MEMBRANE 6125®



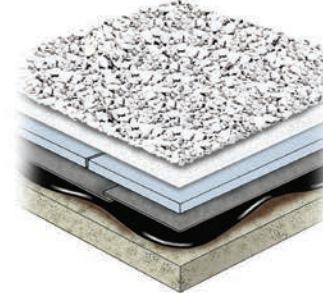



WWW.HYDROTECHMEMBRANE.CA
T. 1-800-361-8924

OTHER TYPICAL APPLICATIONS



BLUE ROOF



GREEN ROOF

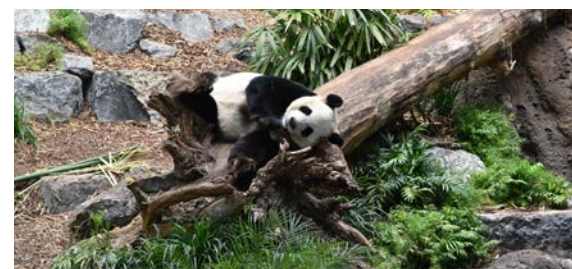

*Da Mao is right at home in Panda Passage.
Photo credit: Calgary Zoo, www.calgaryzoo.com.*

the aluminum profile to the exterior sill (see Figure 2, part 41), creating thermal bridging within the assembly. Calgary experiences significant temperature fluctuations and extreme cold weather conditions, with a winter design temperature of -32°C .⁴ Openings to the exterior would introduce cold air into the system, resulting in higher levels of condensation and freezing of any moisture in the system. Ice build-up inside the system could block the intended drainage path and damage connections along the gutter.

Typical metal skylights glazed with sealed units incorporate pressure equalization and internal drainage without impacting the air barrier or resulting in thermal bridging. RJC suggested these items be revised, as they were not acceptable per industry standards. The proposed spacing between drainpipes was likely inadequate for water to access and expel out of the system and should be revised. The sill should be water- and airtight, with no unsealed openings through the air barrier. RJC suggested providing internal drainage if draining to the exterior was not a possibility without affecting the air barrier. The metal sheet (see Figure 2, part 41) was to be modified to eliminate the thermal bridge through the skylight sill.

The manufacturer revised its design following most of RJC's recommendations. Internal drainage was provided through the condensation gutter and directed to the interior panda space. The layout of the drainpipes was not changed during design revisions. Thermal bridging was mitigated by removing the metal sheet section intended to provide support for the roof membrane tie-in. The final design included tying the air barrier into the aluminum profile, creating a continuous air barrier plane. Figure 3 (on this page) shows the revised section of the system.

3 THERMAL PERFORMANCE

The thermal transmittance (U-Value) for the ETFE aluminum profile was calculated to be $5.90\text{ W/m}^2\text{K}$, $1.9\text{ W/m}^2\text{K}$ for the three layered ETFE cushion and $2.1\text{ W/m}^2\text{K}$ for the combined system.³ These values were calculated by the manufacturer using set temperature parameters of 20°C for the interior and -10°C for the exterior.³ Condensation is expected along the EPDM edge gasket and along the aluminum base. Realistically, a

higher volume of condensation is expected, as Calgary temperatures can reach -32°C during winter. This moisture is intended to drain via a condensation gutter underneath the aluminum profile, and to expel from the system via drainpipes.

To address air- and water-tightness concerns ahead of time, RJC asked for a small corner sample of the aluminum profile that would show the corner joinery and frame sealing. Unfortunately, the corner sample was not provided; rather a small, typical section of the frame arrived and did not show either items. RJC was told that the EPDM cover gasket would be glued at the corners with an EPDM adhesive and that the aluminum frame would not be sealed at the corners. Water that gets through the frame would be captured within the condensation gutter and drained to the interior.

CONSTRUCTION

In the construction industry, it is often expected that as-built details won't always align with the initial design. This is tolerated to a degree, because one cannot predict the exact site conditions during construction. Identifying and correcting these deficiencies during early construction stages is crucial for a project to be on schedule and to avoid additional costs. During installation, deficiencies with the skylight frame and ETFE cushions were noted.

One of the first obvious issues was the inadequate gap at the mitered corners. The aluminum profiles were misaligned so the coupling surfaces at the corners were offset from one another. The misalignment was partially due to the aluminum profile not being set true and level. The structural steel below the aluminum profile was not

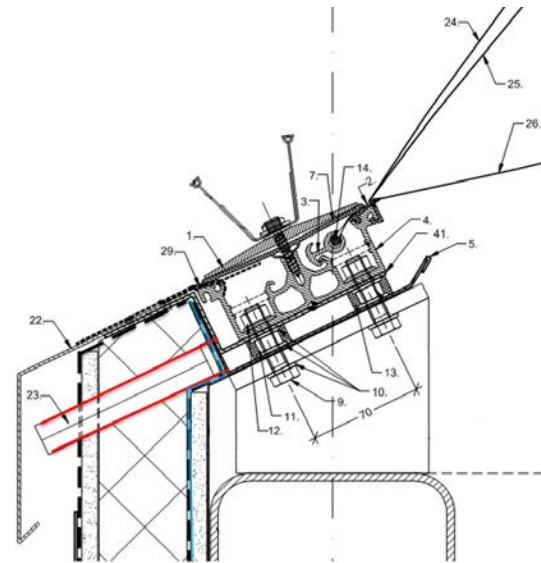

Figure 2. A manufacturer's drawing showing the external drainage (red lines) through the air barrier (blue line).¹

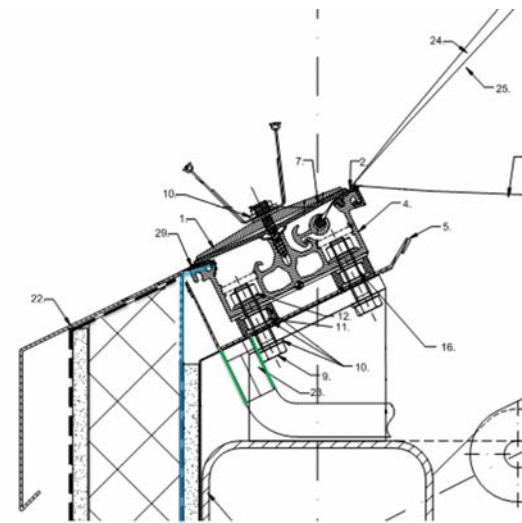
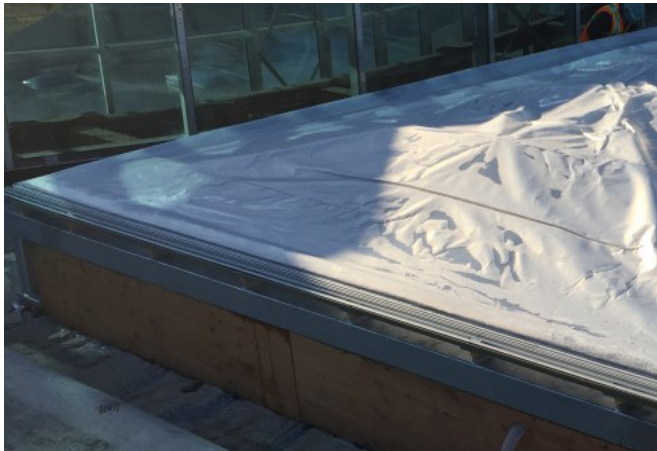

Figure 3. A manufacturer's drawing showing the revised ETFE system with internal drainage (green lines) and the air barrier detail (blue line).¹

PART NO.	PART NAME
1	Aluminum cover profile
2	EPDM edge gasket
4	Aluminum frame profile
5	Condensation gutter
7	EPDM cover gasket
9, 10, 11, 12	Stainless steel hex head bolt, washer, nut
22	Metal sill flashing
23	Condensation drainpipe
24, 25, 26	Outer, middle, and inner layer of ETFE foil
29	Air barrier
41	Metal sheet

Table 1. Parts reference Figures 2 and 3 on this page.





The ETFE skylight above Panda Passage being inflated with a blower.



The steel frame structure for the ETFE skylight.

perfectly level, and the aluminum profile did not incorporate adjustability (e.g., levelling nuts or incremental shims). The suggested improvement was for the contractor to adjust the positioning of the aluminum frame by using adjustable leveling bolts / nuts (see parts 9, 10, and 12 in Figures 2 and 3).

During a subsequent review, standing water was visible in the skylight gutter after a rainfall. This was prior to the ETFE foil being installed. As suspected, water was not draining properly; the system did not incorporate a transitional slope from the north and south elevations (without drain openings), nor to the east and west elevations (with drain openings). The drain layout was not practical for the perimeter of the skylights. Water was actively dripping through the condensation gutter corners and at the bolted connections, indicating that the membrane liner was not continuously sealed in these locations. The repair strategy included installing additional drain openings on the north and south elevations and additional sealing of the corners and the bolted connections.

Once the ETFE cushions were attached to the aluminum profile, they were inflated with the blower. Each skylight was inflated in approximately one hour, with minor adjustments required for the EPDM edge gaskets, which were displaced during the ETFE installation. The contractor used ETFE tape for additional reinforcement at the corners. The air barrier membrane was tied in from the roof deck onto the new built-up curb and tied into the aluminum profile.

In addition to the air barrier membrane, the contractor tied the thermoplastic polyolefin (TPO) single-ply roofing membrane into the aluminum profile, increasing the overall material thickness. This created problems

for installing the EPDM cover gasket and cover plate. The solution was to terminate the TPO membrane at the top of the curb, instead of extending it onto the aluminum profile to allow for sufficient and continuous pressure between the gasket and the air barrier.

The metal sill flashing was installed without a slope, resulting in standing water along the sill and EPDM gasket. The flashing was modified to ensure it slopes away from the cushions and the main gasket. The EPDM cover gasket was glued at the corners and reinforced with an additional EPDM strip, using an EPDM adhesive to reduce the risk of moisture ingress.

Field diagnostic testing such as air leakage characterization and water penetration resistance could not be completed due to project schedule restraints that impeded safe access for testing. Once the building was commissioned to normal interior operating parameters, RJC recommended thermographic scanning from the exterior.

CONCLUSION

Most of the flaws identified during the initial design and construction were corrected during each phase by being proactive with input and discussing concerns with the manufacturer and contractor. As the building envelope consultants, the goal was to ensure the design and installation of the ETFE skylights conformed to industry standards, with the aim of improving the long-term durability of the ETFE skylights and its supporting structure and eliminating air and moisture barrier deficiencies.

By providing recommendations for design loads, air barrier, and drainage components and consistent input during

construction, this goal was achieved. The key benefit of the building envelope consulting services provided by RJC was the team's local knowledge of practical issues that affect building envelopes in Calgary and the ability to bring these to the forefront, assisting the sophisticated ETFE manufacturer from Germany.

Considering this is not a typical product installed by the construction industry in western Canada, several issues were anticipated during design and construction. As this system installation becomes more mainstream in the future, these issues will likely diminish as designers and installers become more familiar with the product.

Jelena Bojanic, B.Sc., EIT, is a building envelope and restoration project engineer at Read Jones Christoffersen Ltd. (RJC). Since joining RJC in 2014, Jelena has gained a variety of project experience in the assessment and restoration of structures and building envelopes.

REFERENCES

1. Seele Cover GmbH, *Shop Drawings and Structural Analysis ETFE Skylights*, Obing Germany, 2017-04-28
2. Peter H. Flueler, Swiss Federal Laboratories for Materials Testing and Research, Flueler Polymer Consulting GmbH, Zurich Switzerland, *ETFE Membrane Structures: And What About Hail Impact Resistance?*, RCI 22nd International Convention, pp. 29-37
3. Seele Cover GmbH, *U-Value, G-Value and Light Transmission ETFE-Cushion*, 2017-06-07
4. Alberta Building Code 2014, Volume 2

